



INSTALLATION REQUIREMENTS - PRIMED & COLORPLUS® PRODUCTS

EFFECTIVE AUGUST 2007

IMPORTANT: FAILURE TO INSTALL AND FINISH THIS PRODUCT IN ACCORDANCE WITH APPLICABLE BUILDING CODES AND JAMES HARDIE WRITTEN APPLICATION INSTRUCTIONS MAY LEAD TO PERSONAL INJURY, AFFECT SYSTEM PERFORMANCE, VIOLATE LOCAL BUILDING CODES, AND VOID THE PRODUCT ONLY WARRANTY.

STORAGE & HANDLING:

Store flat and keep dry and covered prior to installation. Installing siding wet or saturated may result in shrinkage at butt joints. Carry boards on edge. Protect edges and corners from breakage. James Hardie is not responsible for damage caused by improper storage and handling of the product.

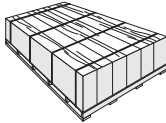

CUTTING INSTRUCTIONS

OUTDOORS

- Position cutting station so that wind will blow dust away from user and others in working area.
- Use one of the following methods:
 - Better:
 - Dust reducing circular saw equipped with a Hardieblade™ saw blade and HEPA vacuum extraction
 - Good:
 - Dust reducing circular saw with a Hardieblade saw blade (only use for low to moderate cutting)

- NEVER use a power saw indoors
- NEVER use a circular saw blade that does not carry the Hardieblade saw blade trademark
- NEVER dry sweep – Use wet suppression or HEPA Vacuum

Important Note: For maximum protection (lowest respirable dust production), James Hardie recommends using "Better" level cutting methods where feasible.

NIOSH-approved respirators can be used in conjunction with above cutting practices to further reduce dust exposures. Additional exposure information is available at www.jameshardie.com to help you determine the most appropriate cutting method for your job requirements. If concern still exists about exposure levels or you do not comply with the above practices, you should always consult a qualified industrial hygienist or contact James Hardie for further information.

SD083105

XLD® TRIM IS A DECORATIVE NON-LOAD BEARING TRIM PRODUCT.

GENERAL REQUIREMENTS:

- Wood or steel backing must be provided for attaching Hardietrim™ XLD® boards.
- A water-resistive barrier is required in accordance with local building code requirements. The water-resistive barrier must be appropriately installed with penetration and junction flashings in accordance with local building code requirements. Flashing is required over horizontal protruding and exposed trim. James Hardie will assume no responsibility for water infiltration.
- Install James Hardie® products with a minimum 6" clearance to the finished grade on the exterior of the building or in accordance with local building codes if greater than 6" is required (fig. 4).
- Maintain a minimum 1/2" clearance between James Hardie trim products and roofs, decks, paths, steps and driveways (figs. 5 & 6).
- Maintain a 1/4" clearance between James Hardie products and horizontal flashing (fig. 7).
- Ensure gutters have end caps. Maintain a minimum 1" gap between end caps and siding & trim (fig.8).
- Install kickout flashing at roof-wall junctions. (fig 9.)
- Adjacent finished grade must slope away from the building in accordance with local building codes - typically a minimum of 6" in the first 10'.
- Do not install James Hardie products such that they may remain in contact with standing water.
- DO NOT use stain on James Hardie® products.

INSTALLATION

Fastener Requirements

2" minimum 16 ga. finish nails or smooth shank siding nails may be used to attach XLD® trim to wood frame construction. ET&F or equivalent fasteners or screws may be used to attach XLD® trim to steel frame construction.

Fastening instructions are similar for all applications. When using finish nails, position nails no closer than 1/2" from the edges of the trim and for all other fasteners no closer than 3/4". Fasteners must be no closer than 1" from ends of trim and spaced a maximum of 16" o.c. Ensure trim is adequately fastened.

Install trim with siding nails staggered at 16" oc (fig 1). When using 12" trim provide an additional row of nails along the center of the trim.

XLD® Trim with ColorPlus® Technology: A finish nail is preferred for installing XLD® trim. Remove laminate sheet as soon as possible after nailing. Nail head touch up can be done before or after removal of the laminate sheet when using finish nails. The preferred method is to touch-up while the laminate sheet is in place. Remove the laminate sheet before paint dries.

Minimum fasteners guide for finish nailing:

	Pre-built corner	Site Built Corners	Other areas (e.g. window trim, band boards and fascia)
4"	1 nail every 16" to attach boards together + 1 nail every 16" each board	2 nails every 16"	2 nails every 16"
6"	1 nail every 16" to attach boards together + 2 nails every 16" each board		
8"	-	3 nails every 16"	3 nails every 16"
12"	-	4 nails every 16"	3 nails every 16"

Use a 2" finish nail to fasten trim together. Longer finish nails may bend.

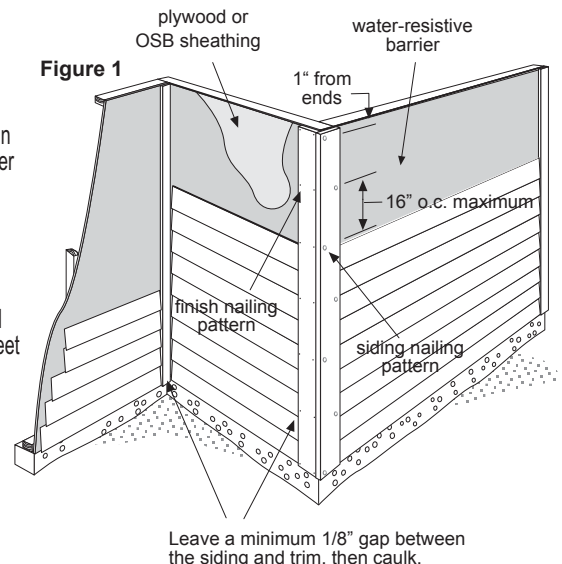

WARNING: AVOID BREATHING SILICA DUST

James Hardie® products contain respirable crystalline silica, which is known to the State of California to cause cancer and is considered by IARC and NIOSH to be a cause of cancer from some occupational sources. Breathing excessive amounts of respirable silica dust can also cause a disabling and potentially fatal lung disease called silicosis, and has been linked with other diseases. Some studies suggest smoking may increase these risks. During installation or handling: (1) work in outdoor areas with ample ventilation; (2) use fiber cement shears for cutting or, where not feasible, use a Hardieblade™ saw blade and dust-reducing circular saw attached to a HEPA vacuum; (3) warn others in the immediate area; (4) wear a properly-fitted, NIOSH-approved dust mask or respirator (e.g. N-95) in accordance with applicable government regulations and manufacturer instructions to further limit respirable silica exposures. During clean-up, use HEPA vacuums or wet cleanup methods - never dry sweep. For further information, refer to our installation instructions and Material Safety Data Sheet available at www.jameshardie.com or by calling 1-800-9HARDIE (1-800-942-7343). FAILURE TO ADHERE TO OUR WARNINGS, MSDS, AND INSTALLATION INSTRUCTIONS MAY LEAD TO SERIOUS PERSONAL INJURY OR DEATH.

SD050905

TRIMMING CORNERS

When installing corners or other vertical trim, position boards on the wall and attach (fig. 1). Use weather cuts sloped away from the wall to join (fig. 3). Alternatively corners can be pre-built (fig. 2).

Pre-Built Corners

Corners can be pre-built off the wall using 2" finishing nails. Each side of the pre-built corner must be secured to the wall (fig. 2).

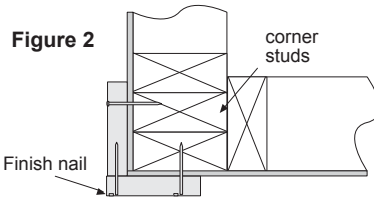

Figure 2

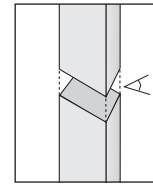

Figure 3

22.5° - 45°
water cut

CLEARANCES

Install siding and trim products in compliance with local building code requirements for clearance between the bottom edge of the siding and the adjacent finished grade.

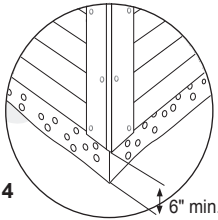

Figure 4

Maintain a minimum 1/2" clearance between James Hardie® trim products and decks, paths, steps and driveways.

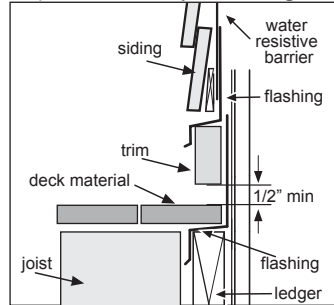

Figure 5

At the juncture of the roof and vertical surfaces, flashing and counterflashing shall be installed per the roofing manufacturer's instructions. Provide a 1/2" clearance between the roofing and the bottom edge of the siding and trim.

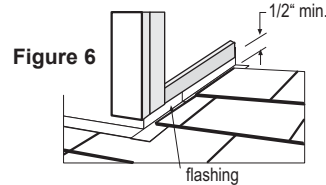

Figure 6

Maintain a 1/4" clearance between the bottom of James Hardie products and horizontal flashing. Do not caulk gap.

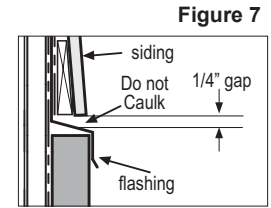

Figure 7

Maintain a minimum 1" gap between gutter end caps and siding & trim.

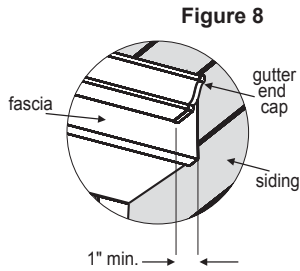

Figure 8

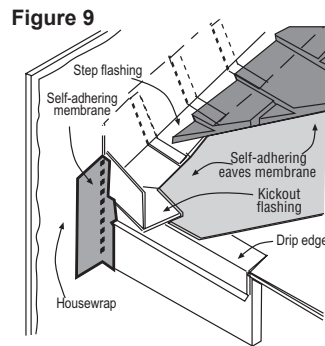

Figure 9

KICKOUT FLASHING

Because of the volume of water that can pour down a sloped roof, one of the most critical flashing details occurs where a roof intersects a sidewall. The roof must be flashed with step flashing. Where the roof terminates, install a kickout to deflect water away from the siding.

It is best to install a self-adhering membrane on the wall before the subfascia and trim boards are nailed in place, and then come back to install the kickout.

Figure 9, Kickout Flashing⁺ To prevent water from dumping behind the siding and the end of the roof intersection, install a "kickout" of sufficient length and angle to direct the water running down the roof away from the siding.

TRIM APPLICATION FOR WINDOWS, DOORS & OTHER OPENINGS

Trim the opening prior to the installation of the siding (fig. 10)

NOTE: Follow your window/door manufacturers installation instructions.

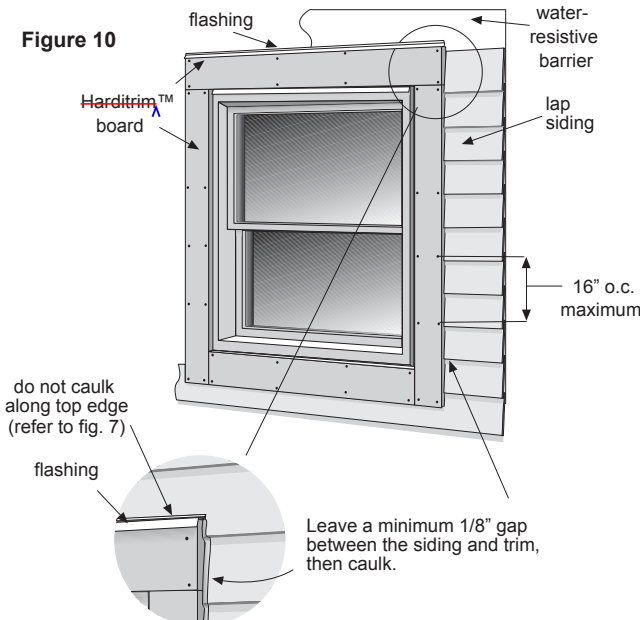

Figure 10

BAND BOARDS, FRIEZE BOARDS, RAKE TRIM & FASCIA

Hardietrim XLD® boards may also be used as band boards, frieze boards, rake trim or fascia (fig. 11).

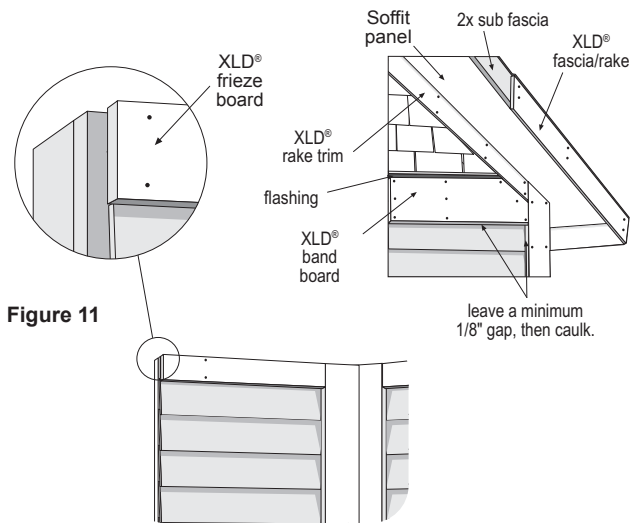

Figure 11

* The illustration (figure 9) was reprinted with permission of THE JOURNAL OF LIGHT CONSTRUCTION. For subscription information, call (800) 375-5981 or visit www.jlconline.com.

FASCIA

For fascia applications, a flashing is required over top of the fascia (fig. 12).

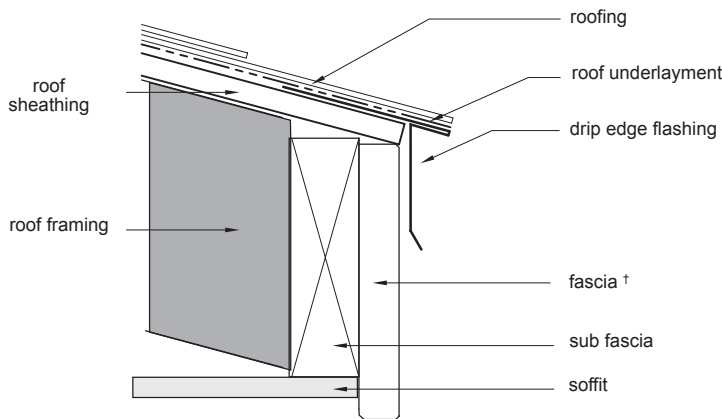

Figure 12

† Ensure adequate fastening of fascia

BAND BOARD

A flashing is required over the trim (fig. 13).

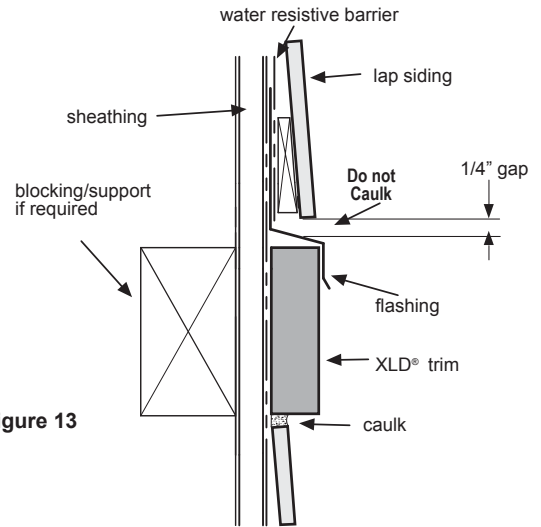

Figure 13

GENERAL FASTENING REQUIREMENTS

Fasteners must be corrosion resistant, galvanized, or stainless steel. Electro-galvanized are acceptable but may exhibit premature corrosion. James Hardie recommends the use of quality, hot-dipped galvanized nails. James Hardie is not responsible for the corrosion resistance of fasteners. Stainless steel fasteners are recommended when installing James Hardie® products near the ocean, large bodies of water, or in very humid climates.

- Drive fasteners perpendicular to the trim and framing.
- Do not over-drive siding nails.
- Do not drive nails at an angle.
- For wood framing, under driven nails should be hit flush to the trim with a hammer (for steel framing, remove and replace nail).
- **Do not use aluminum fasteners, staples, or clipped head nails.**

PNEUMATIC FASTENING:

XLD® trim can be hand nailed or fastened with a pneumatic tool. Pneumatic fastening is highly recommended. Finish nails can be slightly overdriven or recessed to allow concealing of the nail head (fig. A). When using siding nails set air pressure so that the fastener is driven snug with the surface of the siding (fig. B). A flush mount attachment on the pneumatic tool is recommended. This will help control the depth the nail is driven. If setting the nail depth proves difficult, choose a setting that under drives the nail. (Drive under driven nails snug with a smooth faced hammer - Does not apply for installation to steel framing).

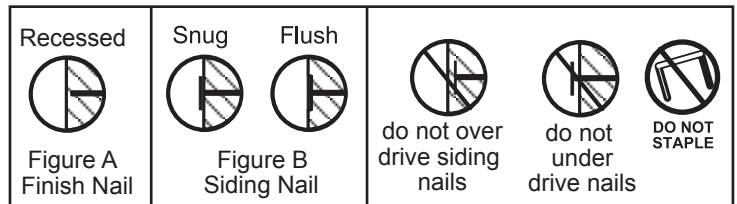

CAULKING

For best results use an Elastomeric Joint Sealant complying with ASTM C920 Grade NS, Class 25 or higher or a Latex Joint Sealant complying with ASTM C834. Caulking/Sealant must be applied in accordance with the caulking/sealant manufacturer's written instructions or ASTM C1193.

PAINTING

DO NOT use stain on James Hardie® products. James Hardie products must be painted within 180 days for primed product and 90 days for unprimed. 100% acrylic topcoats are recommended. Do not paint when wet. For application rates refer to paint manufacturers specifications. Back-rolling is recommended if the siding is sprayed.

COLORPLUS® TECHNOLOGY CAULKING, TOUCH-UP & LAMINATE

- Touch up nicks, scrapes and nail heads using the ColorPlus® technology touch-up applicator. Touch-up paint should be used sparingly. If large areas require touch-up, replace the damaged area with new XLD® trim with ColorPlus technology.
- Laminate sheet must be removed immediately after installation of each course.
- Terminate non-factory cut edges into trim where possible, and caulk. Color matched caulks are available from your ColorPlus product dealer.
- Treat all other non-factory cut edges using the ColorPlus technology edge coat, available from your ColorPlus® product dealer.

PAINTING JAMES HARDIE® SIDING AND TRIM PRODUCTS WITH COLORPLUS® TECHNOLOGY

When repainting ColorPlus products, James Hardie recommends the following regarding surface preparation and topcoat application:

- Ensure the surface is clean, dry, and free of any dust, dirt, or mildew
- Repriming is normally not necessary
- 100% acrylic topcoats are recommended
- Oil/alkyd base paints or semi transparent stains are not recommended
- Apply finish coat in accordance with paint manufacturers written instructions regarding coverage, application methods, and application temperature

RECOGNITION: Hardietrim™ XLD® boards may be installed as an equal alternative to conventional trim permitted for use in; the 1997 Uniform Building Code, Section 601.5.5; the 1997 Standard Building Code, Section 1404.1; the 1999 BOCA National Building Code, Section 1407.2.2; 2003 International Building Code, Section 1402.1, the 2003 International Residence Code for One - and Two - Family - Dwellings, Section R703.1. the 2003 International Residence Code for One - and Two - Family - Dwellings, Section R703.1. and the 1998 International One-and -Two -Family Dwelling Code, Section 601.1.

