

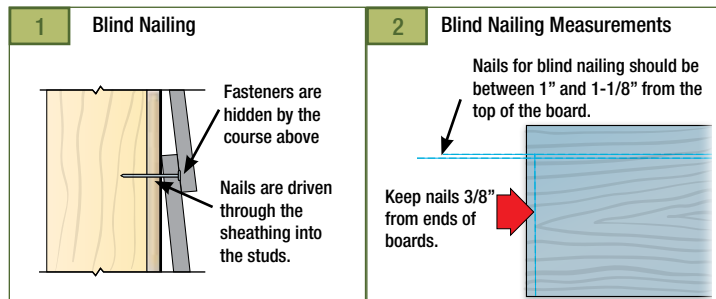

Scope: This Technical Bulletin addresses approved fastening techniques when using HardiePlank® Lap Siding.

Blind Nailing (Preferred Installation)

James Hardie prefers and recommends installation of HardiePlank® Lap Siding by the blind nailing technique, such that fasteners are hidden by the course above. Fasteners shall be installed between 1 in and 1-1/8 in. from the top edge and no closer than 3/8 in. from the ends of the plank. HardiePlank® lap siding may be used with fasteners approved by ICC-ES NER-405 spaced in accordance with the Wind Load Tables. Fasteners must be corrosion resistant, galvanized or stainless steel.



Pin Backs

Pinning the plank down at the bottom edge is a common practice called "pin back." It is used to correct "high nailing", loose planks, gaps or rattling. Pinning of the butt joints with is not intended to increase wind load values; and shall be installed 3/8" from end and between 3/4" and 1" from bottom edge. The finish nail shall be nailed flush to the surface (not countersunk), must be corrosion resistant (e.g. galvanized or stainless) and does not provide structural support. For best aesthetics nail heads should be touched up to color match.

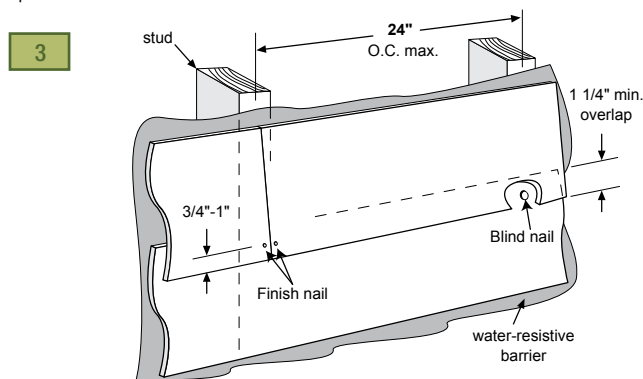

Face Nailing

Face nailing is applicable where dictated by building code, in high wind areas, and when fastening is to OSB or equivalent sheathing without penetrating into studs. Face nailing exposes the fastener head to the elements and allows for the fastener to penetrate through two sheets of overlapped plank.

Fasteners shall be installed between 3/4" and 1" from the bottom edge of the board and the head must be snug, not counter-sunk or overdriven.

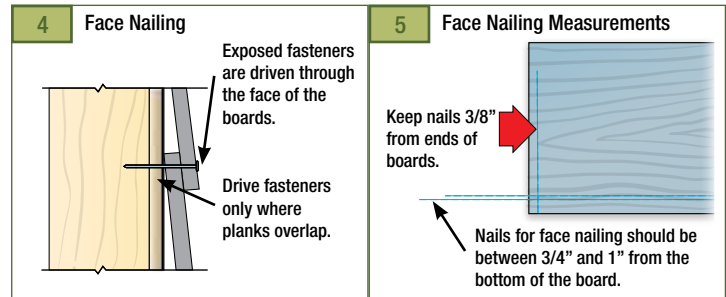

The use of roofing nails (11GA) are not approved in this application. Where ColorPlus® products are used, the fastener head must be touched-up for color match.

Fastener Selection For Face Nailing

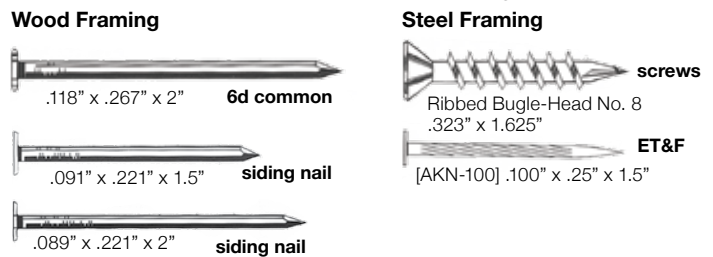

Double Nailing

Double nailing refers to the combined use of blind nailing and face nailing. Double nailing may be applicable in circumstances of repair or when a correction is necessary to meet fastening requirements that would otherwise require replacement of the siding.

Additional care must be taken to assure that fastening of the face nail does not contact the blind nail and that spacing does not induce damage to the lapped plank.

With double nailed assemblies, the wind load value for face nailing is not additive to the wind load value for blind nailing. To determine the wind load value for a double nailed assembly locate the blind nailing and the face nailing wind values as listed in the product's evaluation report (ICC-ES NER-405), the greater of the two wind load values shall be used.

These installation details are intended to be used as a guide, only. For proper product installation refer to the manufacturer's instructions and consult with an architect or Licensed Design Professional. All national, state, and local building code requirements must be followed and where they are more stringent than James Hardie installation requirements the state or local requirements will take precedence. If you have any questions regarding this matter please contact our Technical Services Desk at 1-800-942-7343.

DESIGN ADVICE: Any information or assistance provided by James Hardie in relation to specific projects must be approved by the relevant specialists engaged for the project eg. builder, architect or engineer. James Hardie will not be responsible in connection with any such information or assistance.

IMPORTANT: Failure to install and finish this product in accordance with applicable building codes and James Hardie written application instructions may affect system performance, violate local building codes, void the product-only warranty and lead to personal injury.